



DATE: TAG:
 JOB:
 PROJECT:
 COMPANY:
 SALES PERSON:

5L5@K 5F9<CI G9'9L<5I GH: 5B
 577 9GGC FM-6C @5HC F'A CI BHB; 'F5-@Z<CF-AC B15@

: 95H F9G

% A ci bh]b['fU]g'hc 'VY'g\]ddYX 'ccg' 'k]h \UfXk UfY"
 &" -g: 'Uhc fg'UfY 'g dd]YX 'UgdYf'cfXYf"

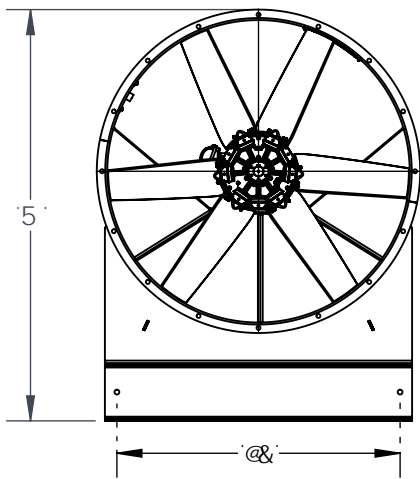

<CF-AC B15@65G9'A CI BH

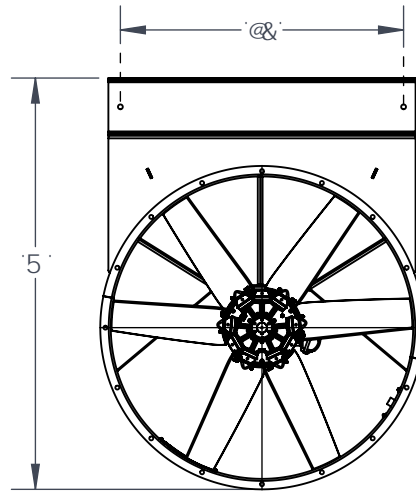

<CF-AC B15@79-@B; <I B;

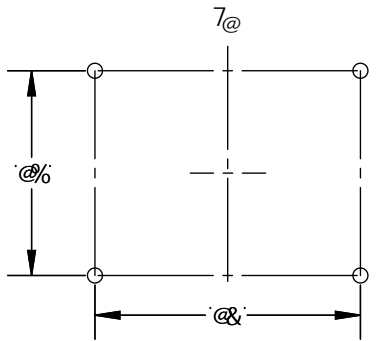

: CI B85HC B D@5B J -K

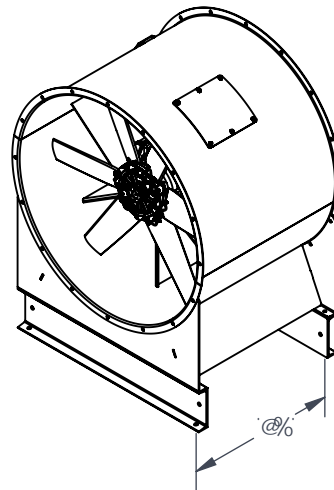

8-A 9BGC B5@85H5.

SIZE	A	L1	L2	MOUNTING RAIL SECTION	MAX. MTR. FRAME	LVL-1, FAN WEIGHT (LESS MOTOR)	LVL-2, FAN WEIGHT (LESS MOTOR)
AWX-1600	85 3/4	45 1/2	59	C12 X 30	326T	1112	1093

5@@8-A 9BGC BG5F9-B B7 <9G'5B8 'K 9# <HG'5F9-B '@G"

REVISION:

FORM:

REPLACES: